

TOF Sensor
TOF-1Sn
TOF-1St

Operating and Instruction Manual

EN

Measuring 1-D TOF Sensor for
Presence and Motion Detection

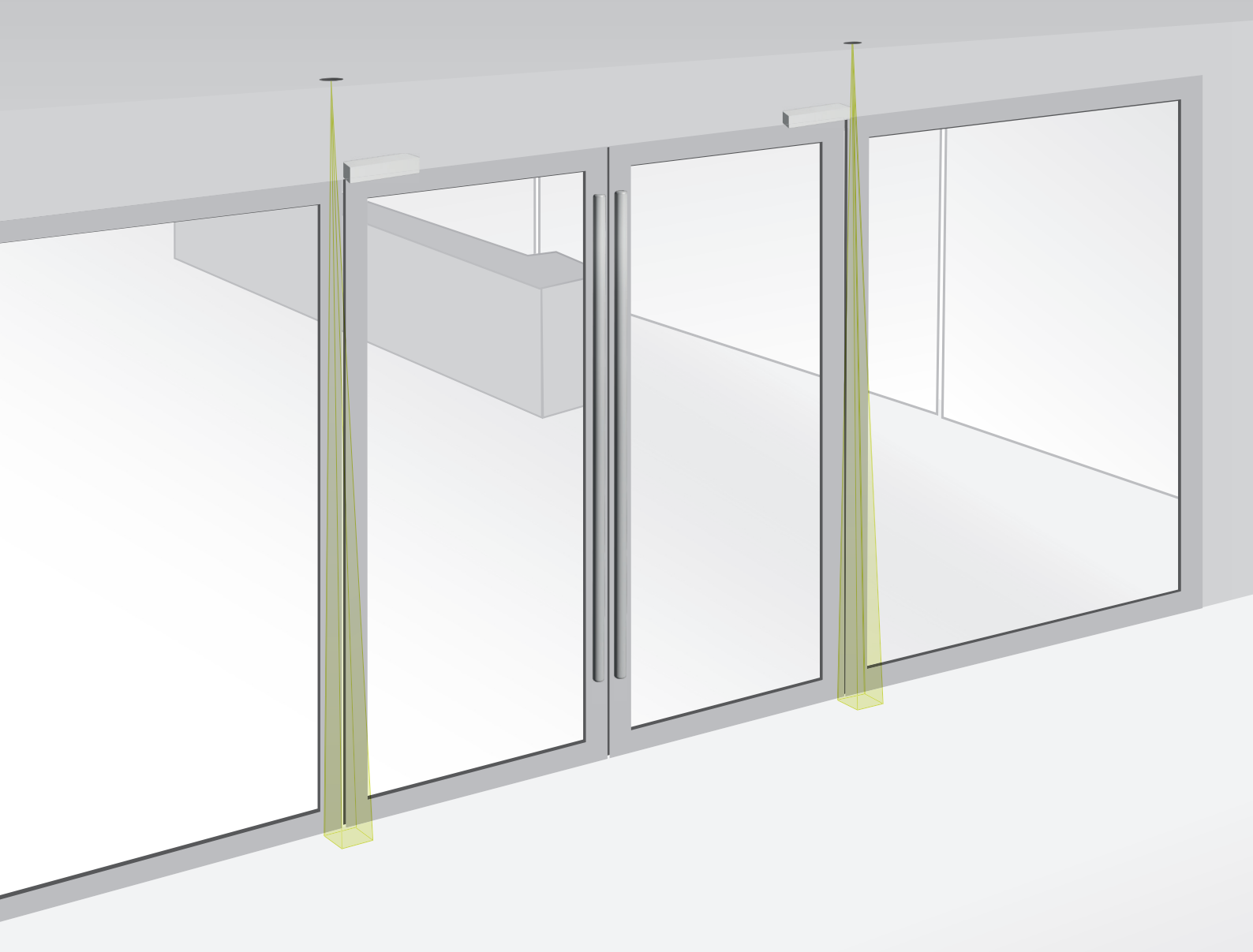

Operating and Instruction Manual

EN

Order designation: Measuring 1-D TOF sensor for presence and motion detection

Art.No. 10001720, 10001722, 10001748

Table of contents

1. Introduction	3
1.1 About this manual	3
1.2 Safety information – IMPORTANT! READ BEFORE INSTALLATION!	3
1.2.1 To ensure safe conditions:	3
1.2.2 Non-intended use	4
1.3 Symbols, safety messages	4
1.3.1 Safety messages categories	4
1.3.2 Informative notes	5
1.4 Declaration of conformity	5
2. Scope of delivery and device description	5
2.1 Delivery package	5
2.2 Device description	5
2.3 TOF-1S Product overview	7
2.4 Type description	7
2.5 Features of the TOF-1S	7
2.6 Application examples	7
3. Overview	8
3.1 Detection area dimensions	8
3.2 Alignment	9
4. Configuration and operation	9
4.1 N type (Potentiometer)	10
4.2 T type (Teach-in)	11
5. In- / Output description	12
5.1 Universal output (relays output)	12
5.2 Logic selector	12
6. Installation	13
6.1 Mounting of snap-in housing	13
7. Electrical connection	13
8. Start-up	14
9. Timing diagram	14
10. LED signals	14
11. Trouble shooting	15
12. Maintenance	15
13. ESD-Safety	15
14. Decommissioning	15
15. Disposal	16

Sensotek GmbH

Specialist for entrance automation within the Pepperl+Fuchs Group

Stuttgarter Str. 119, 73061 Ebersbach (Fils), Germany

Tel.: +49 7163 93926-0, Fax: +49 7163 93926-10, info@uk.sensotek.com

1. Introduction

1.1 About this manual

This document contains information you need to use your product in the applicable phases of the product life cycle. This may include

- Product identification
- Delivery, transport, and storage
- Assembly and installation
- Commissioning and operation
- Maintenance and repair
- Troubleshooting
- Disassembly
- Disposal

The documentation consists of the following parts:

- Operating and installation instructions (= this document)
- Data sheet

In addition, the documentation may consist of the following parts, if applicable::

- Certificate of conformity
- Certificates

1.2 Safety information – IMPORTANT! READ BEFORE INSTALLATION!

The TOF-1S was developed and manufactured using state-of-the-art systems and technologies. However, injury and damage to the sensor can still occur.

1.2.1 To ensure safe conditions:

- Read all enclosed instructions and information.
- Follow the instructions given in this manual carefully.
- Observe all warnings included in the documentation and attached to the sensor.
- Do not use the sensor if it is damaged in any way.
- Keep the instruction manual on site.

The TOF-1S should only be installed by authorized and fully trained personnel! The installer or system integrator is fully responsible for the safe integration of the sensor. It is the sole responsibility of the planner and/or installer and/or buyer to ensure that this product is used according to all applicable standards, laws and regulations in order to ensure safe operation of the whole application.

Any alterations to the device by the buyer, installer or user may result in unsafe operating conditions. Sensotek GmbH is not responsible for any liability or warranty claim that results from such manipulation.

Failure to follow instructions given in this manual and/or other documents related to the TOF-1S may cause customer complaints, serious call backs, damage, injury or death.

1.2.2 Non-intended use

TOF-1S **must not be** used for:

- Protection of dangerous machine
- Equipment in explosive atmospheres
- Equipment in radioactive environments



Use only specific and approved safety devices for such applications, otherwise serious injury or death or damage to property may occur!

1.3 Symbols, safety messages

Symbol	Meaning
■	Single instruction or measures in no particular order
1. 2. 3.	Sequenced instructions
■	List, in no order of importance
→	Reference to a chapter, illustration or table within this document
Important	Important information for the correct use of the sensor

This document contains symbols to indicate warnings and informativenotes.

1.3.1 Safety messages categories

Warning notices are always provided when your actions could pose a hazard.

It is essential that you observe these warning notices for your own personal safety and to avoid damage to property.

Depending on the level of risk, the warning notices are displayed in descending order as follows:



Danger!

This symbol warns you of an imminent danger.

Failure to observe this warning may result in personal injury or death.



Warning!

This symbol warns you of a possible malfunction or danger.

Failure to observe this warning may result in personal injury or serious damage to property.



Caution!

This symbol warns you of a possible malfunction.

Failure to observe this warning may result in the product or connected systems and equipment malfunctioning or failing completely.

1.3.2 Informative notes



Notes:

This symbol indicates important information.

1.4 Declaration of conformity

EC-Declaration of conformity – Extract

The TOF-1S product complies with the following directives and harmonized standards:

EU-Richtlinien/EU-Regulation	Normen/Standards
2006/42/EC / Supply of Machinery (Safety) Regulations 2008	EN 12015:2014
2014/30/EU / Electromagnetic Compatibility Regulations 2016	EN 12016:2013
2014/35/EU / Electrical Equipment (Safety) Regulations 2016	EN 61000-6-2:2019
2011/65/EU / The Restriction of the Use of Certain Hazardous Substances in Electrical and Electronic Equipment Regulations 2012	EN 61000-6-3:2007+A1:2011
	EN 60068-2-6:2008
	EN 60068-2-27:2009
	EN 60068-2-14:2009
	EN 60068-2-78:2013

The full declaration of conformity can be downloaded at www.sensotek.com.

2. Scope of delivery and device description

2.1 Delivery package

A delivery package contains:

- 1 × TOF-1S sensor with pigtail cable
- 1 × Connection cable (2 m)
- 1 × Installation guide (depends on the type ordered)

2.2 Device description

The TOF-1S is a compact yet powerful single-spot measuring system with the widest range of application possibilities. It uses Time-of-Flight technology (TOF) to ensure ultra reliable detection and exact detection range setting, regardless of the background. This enables a detection range of up to 6 m (20 ft).

The sensor can measure the exact distance at which a person or object enters the detection area or it can simply switch the output at a predefined level. This means the potential application areas are immense: from optimizing warehouse door opening times, to providing touchless button functionality. Its small dimensions mean the TOF-1S is ideal as a built-in solution.

Technical Data

General data

EMV emission	EN 12015:2014 EN 61000-6-3:2007, +A1:2011
EMV Immunity	EN 12016:2013 EN 61000-6-2:2019
Vibration	IEC 60068-2-6:2007
Shock	IEC 60068-2-27:2008
RoHS	2011/65/EU
Certificate	CE

Optical

Operating range	0.2 ... 6 m
- T Type	0.2 ... 3 m
- N Type	0.2 ... 3 m
Active light spot at 2 m distance	20 mm × 20 mm
Offset	
- T Type	0.15 m (from background)
Measurement precision	±5 % at 2 m ±10 cm over the whole range
Max. ambient light	100.000 Lux

Mechanical

Dimensions	Ø 29.5 mm × 35.8 mm
Housing material	Polycarbonate
Housing color	Black
Enclosure rating	IP65
Temperature range	-40 °C ... +60 °C
Relative humidity (non-condensing)	0 ... 95 %

Electrical

Supply voltage U_{sp}	10 ... 30 V DC
Current consumption at 24 VDC	50 mA
Peak current consumption during 500 mA power up at 24 VDC	500 mA
Outputs	Solid-state relay, NO/NC configurable
Max. switching voltage	60 V DC
Max. switching current	150 mA
Max. power-up time	1 s
Max. response time	60 ms

Sensor: Connection cable and electrical connections

Length	0.25 m
Connection	Screwable, M8, 6-pin
Diameter	Ø 4.2 mm
Material	PVC, black
Plug color	Blue

Connection cable and electrical connections

Length	2 m (other lengths on request)
Connection	Screwable, M8, 6-pin
Diameter	Ø 4.2 mm
Material	PVC, black
Plug color	Blue
Wires	AWG26
▪ brown	+USP
▪ black	Output A
▪ green	Output B
▪ blue	GND (0 V)
▪ white	Not used
▪ gray	Logic selector

2.3 TOF-1S Product overview

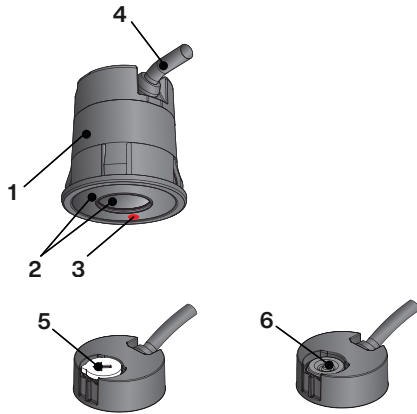

1. Snap-in housing
2. Optical window
3. Status LED
4. Connection cable
5. Potentiometer
6. Teach-in button and cap

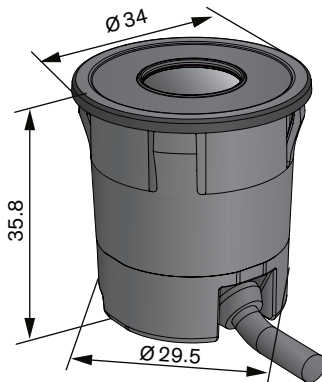

Fig. 1: Overview TOF-1S; all dimensions in mm

2.4 Type description

TOF-1Sn: Potentiometer

TOF-1St: Teach-In

2.5 Features of the TOF-1S

- Exact distance setting, independent of background
- Excellent detection capability
- Insensitive to ambient light
- Easy mounting
- Compact and sleek design
- Operating range of up to 6 m

2.6 Application examples

- Closing edge safety device on hinged doors
- Safety device on sliding doors
- Closing edge safety device on automatic windows

3. Overview

Based on Time-of-Flight technology (TOF), the TOF-1S consists of an active infrared emitter and receiver combined in the same housing. There is one size of spotlike detection area available which reflects an exact picture of the safeguarded area.

One output signals the detection of an object within the detection area.

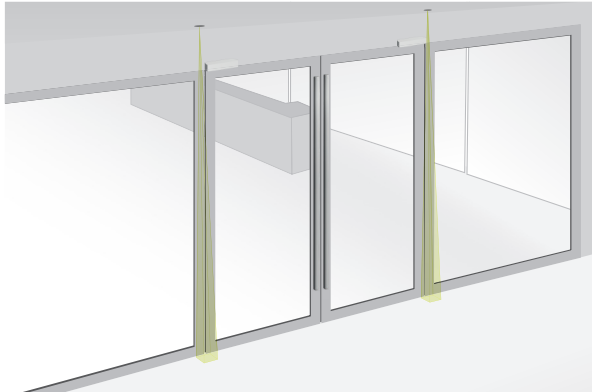

Fig. 2: Closing edge safety device on hinged doors



Fig. 3: Safety device on sliding doors



Fig. 4: Closing edge safety device on automatic windows

3.1 Detection area dimensions

The maximum detection range is 6 m (20 ft). Object detection at a range less than 0.2 m (0.7 ft) cannot be guaranteed.

The TOF-1S features a detection area of 20 mm × 20 mm at 2 m (0.79 in × 0.79 in at 6.5 ft) range. It reads the correct distance and switches the output reliably for objects covering the full beam size (detection area). For objects being only partially in the detection area, a correct distance evaluation cannot be guaranteed.

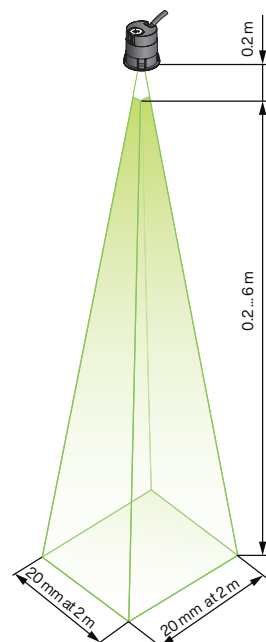

Fig. 5: Dimensions of the detection area

As the illumination size is bigger than the detection size, at 2 m (6.5 ft) range, the TOF-1S needs at least 20 cm (7.87 in) space to the next sensor to avoid interference.

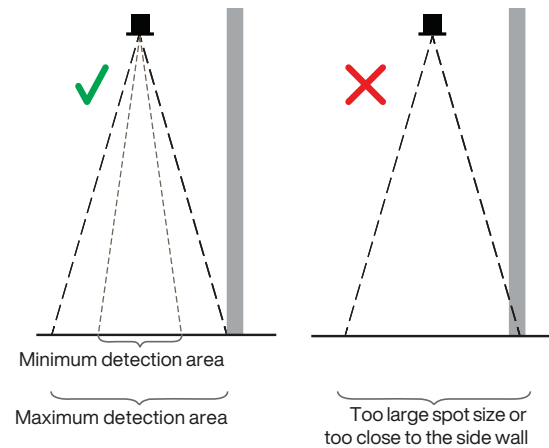
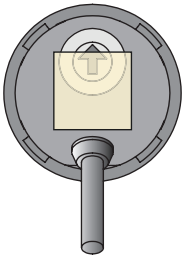

Fig. 6: Illumination size of the TOF-1S

3.2 Alignment

As the detection area of the TOF-1S looks like a square, it is important to know where the flat borders and where the edges are:



Important:

- For proper functionality, the remission range of the background or the object has to be between 2 ... 90%.
- Do not use high reflective, retro-reflective or mirroring backgrounds or objects. They can lead to malfunction of the sensor due to the emitted beam not being directly remitted back to the sensor, which leads to measurements out of the operating range.

4. Configuration and operation

There are different TOF-1S types available. Some of them need to be set manually, others are factory set.

Important:

The sensor uses a ± 40 mm (± 1.57 in) hysteresis. The hysteresis is the difference between the switching points changing the status from “free field” to “object detected” and back from “object detected” to “free field” compared to the nominal limit.

4.1 N type (Potentiometer)

The detection range can be individually set to between 0.2 m and 3 m (0.7 ft and 10 ft) using the potentiometer located at the rear of the sensor.

Important:

When setting with the potentiometer, use Fig. 12 as the settings are not printed on the sensor. Take a small screw driver and turn the potentiometer to the required position.

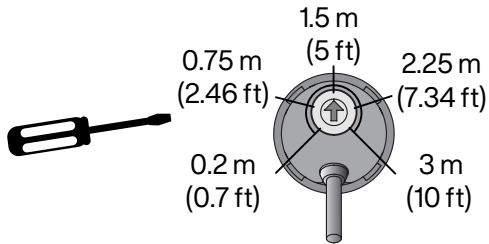

Fig. 7: Example of an adjustment between 0.2 m and 3 m

Preset:

- Set the potentiometer to the limit value before the sensor is mounted..

Setting the switching distance:

- Mount the sensor at its final position.
- Place an object (or person) at the desired limit distance.
- Turn the potentiometer clockwise, starting at the left, until the LED shines bright.
- Turn it back slowly until the LED dims.
- Now the limit is set to the correct distance.

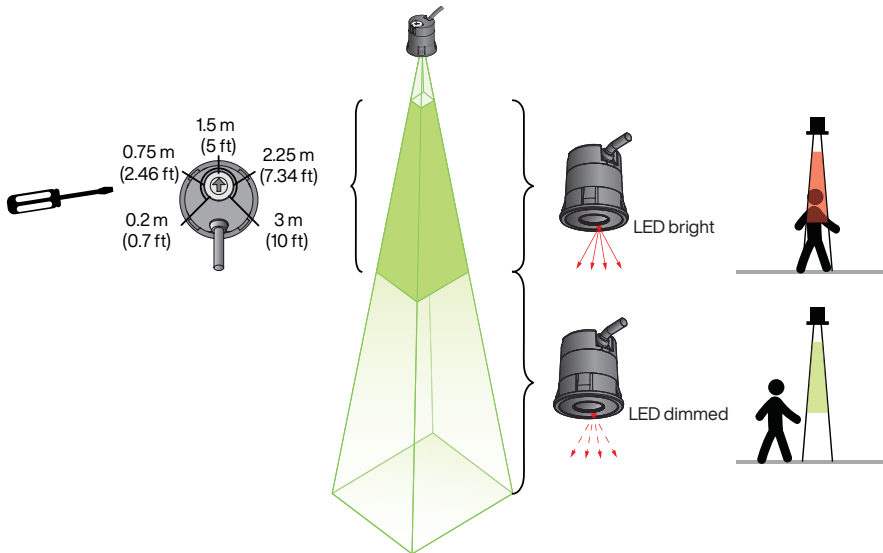

Fig. 8: Configuration - N type

4.2 T type (Teach-in)

The T type features a teach-in function that can be initiated in two ways:

1. Exchange of the polarity of the supply voltage (brown wire to GND and blue wire to USP)

With the exchanged connection of GND and USP, the sensor is put into a setting mode and learns the distance to the background. The status LED starts to blink. To indicate that the calibration is finished, the sensor stops blinking and stays red for about 30 s. Now the wiring of the TOF-1S has to be adjusted according to the electrical connections (brown wire to USP and blue wire to GND).

The teach-in mode is an endless loop of 30 s setting time (blinking LED) followed by a 30 s break (red LED). In this mode, the sensor is not operational for object detection.

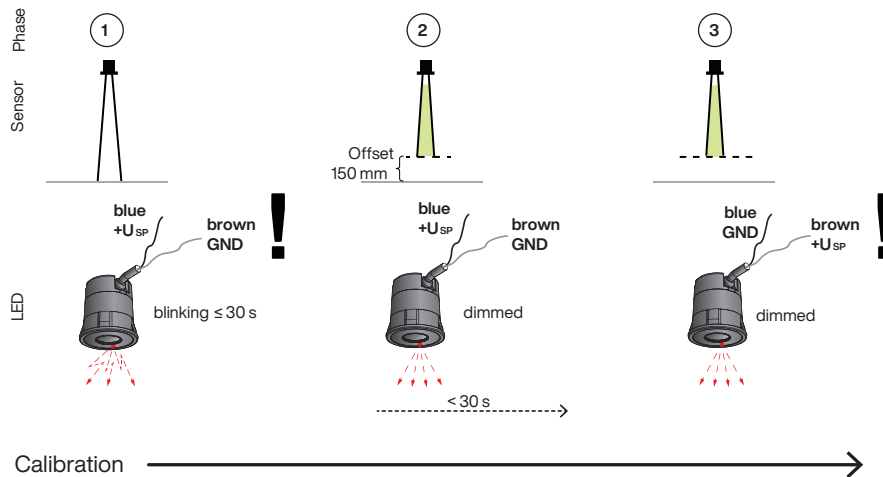

Fig. 9: Configuration T type - exchange of the polarity

2. Setting with the teach-in button

There is a button located at the back of the sensor. When the teach-in button is pressed for at least 2 s, the LED blinks for 30 s; the detection area (distance to the background minus 150 mm (5.9 in)) is saved and the LED dims. As soon as a person or object enters the detection area, the sensor switches the output. The set switching distance can only be changed by pressing the teach-in button again.

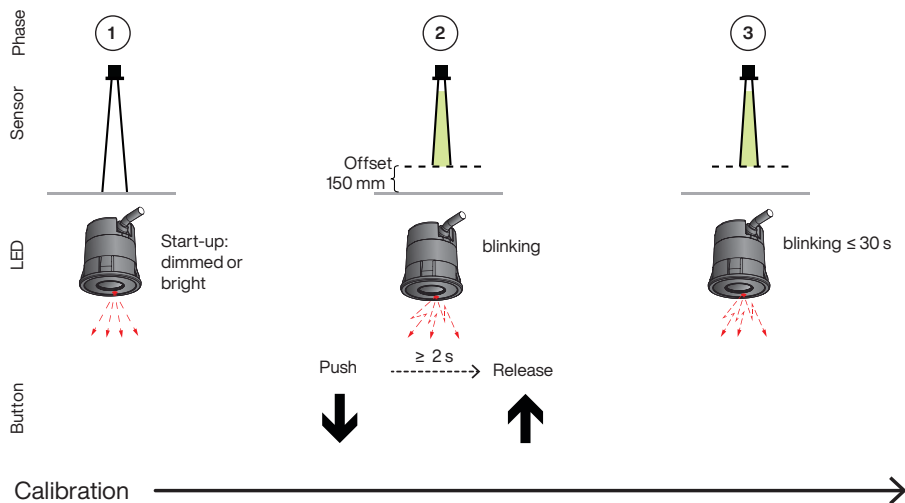

Fig. 10: Configuration T type with the teach-in button

Important:

- Be aware that the set switching level is always about 150 mm (5.9 in) above the background.
- A background within the maximal detection range is used to calibrate the sensor. If there is none, an object has to be used for simulating a background. A calibration into nothingness does not work.
- When the power is switched off the sensor remembers the last setting as the switching distance. This distance can only be changed by repeating the teach-in process.

5. In- / Output description

There are different possibilities of in- and outputs. Please be aware that not all variants can be used with every type.

5.1 Universal output (relays output)

The TOF-1S features an universal (solid-state-relay) output. With the help of the logic selector, the output signal can be configured according to the controller requirements for “normally open” or “normally closed” operation.

5.2 Logic selector

Output logic is set using the gray wire. The logic will be defined by the power-up sequence. After the power-up the logic will not change until the next power-up is made.

It is recommended to keep the logic selector input tied to the desired voltage level during operation.

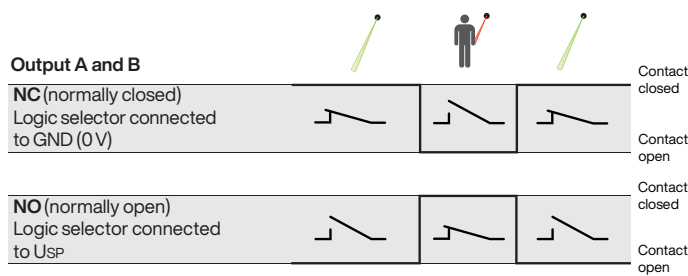

Fig. 11: Logic selector

6. Installation

It is recommended to carry out the system installation according to the following steps:

1. Check if the scope of delivery is complete.
2. Mark clearly that the modifying system is out of service and switch off main power and door control unit.
3. The installation place needs to fulfill the criteria detailed in Chapter 5.1.
4. Drill a hole at the required position (see drilling template for flush and surface mounting).
5. If needed, mount the mounting bracket.
6. Snap in the sensor at the defined position.
7. Connect the TOF-1S with the controller.

6.1 Mounting of snap-in housing

The mounting hole recommended for flush mounting is 30 to 31 mm. The sheet thickness cannot be greater 3 mm.

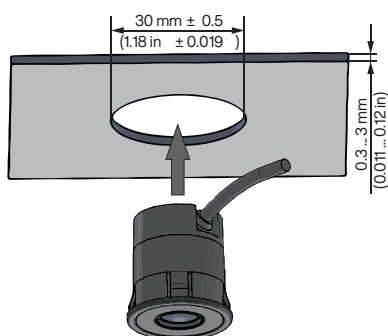

Fig. 12: Mounting of snap-in housing

7. Electrical connection

Depending on the selected supply voltage and output, there are two different options:

Relay output

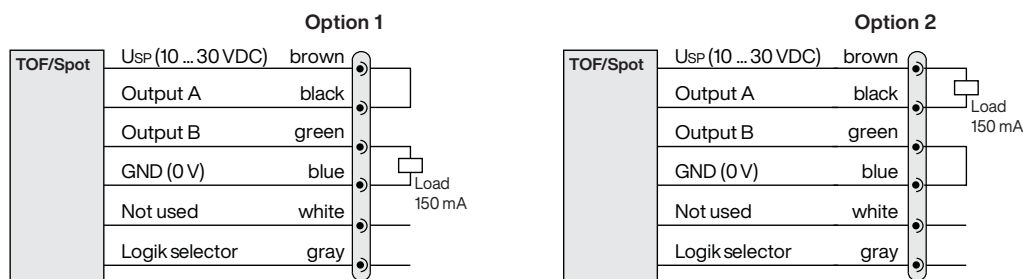

Fig. 13: Solid-state relay output

Important:

- The Output A and Output B are interchangeable.
- Any unconnected (n.c.) wires have to be separated and isolated.

8. Start-up

1. Switch on mains and power up the door control unit.
2. Check if LED lights up.
3. Check the distance setting and the reaction of the sensor, including the status LED, by placing a hand into the detection area at different heights.

9. Timing diagram

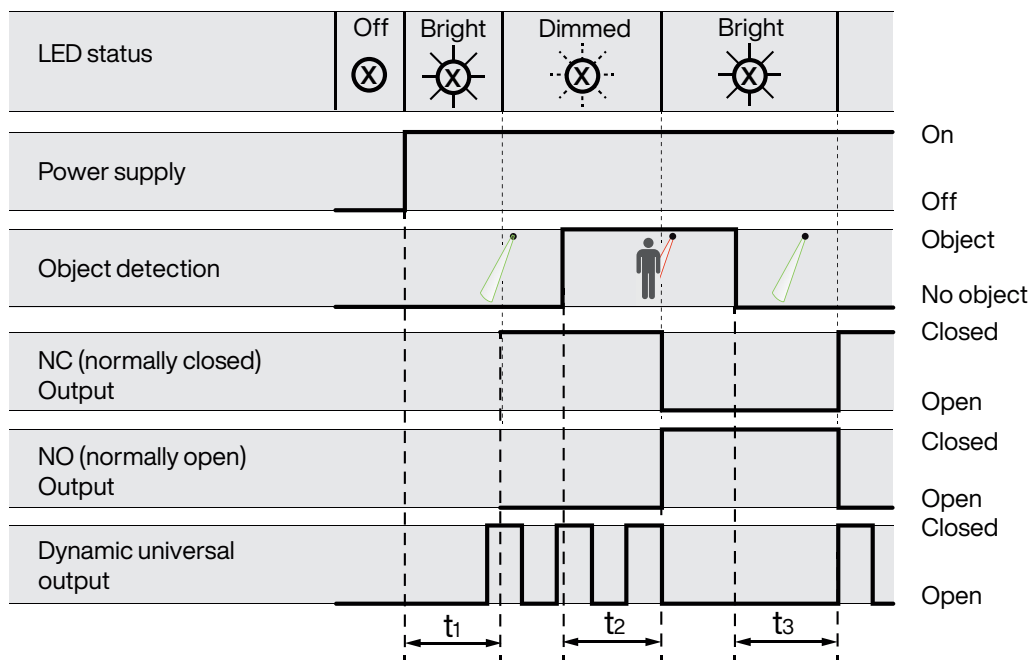

Fig. 14: Timing diagram for relay output

	Time	Value
Power-on time	t_1	1,000 ms
Response time	t_2	≤ 60 ms
Release time	t_3	≤ 60 ms

Table 1: General timing table

	Value
Output A and B (relay)	Voltage pin to GND
	Voltage between pins
	Current
	-30 ... +30 V
	-60 ... +60 V
	< ± 150 mA

Table 2: General value table

10. LED signals

LED status	Description
LED off	No power
LED dimmed red	No object detected
LED bright red	Object detected
LED blinking (T type only)	Distance setting active

11. Trouble shooting

Status	Action
LED off	<ul style="list-style-type: none">■ Check supply power■ Check electrical connections
Object in the safeguarded area and LED dimmed red	<ul style="list-style-type: none">■ Check distance setting■ Check alignment
No object in the safeguarded area and LED bright red	<ul style="list-style-type: none">■ Check electrical connections■ Check distance setting■ Check alignment

If the problem persists, please contact Sensotek GmbH (+49 7163 93926-0; info@de.sensotek.com; www.sensotek.com).

12. Maintenance

Although the TOF-1S does not need regular maintenance, a periodical functional check is strongly recommended as follows:

- Check the mounting position and detection area of the sensor
- Clean the optical window with a soft towel and a little soapy water



Notice: Damage to the optical window

Never use any solvents, cleaners or mechanically abrasive towels or high pressure water to clean the sensors.

13. ESD-Safety



Warning! The device contains sensitive electronic components that may be affected by electrostatic discharge (ESD). Use appropriate ESD protection measures, such as wrist straps, to protect the device from damage.

14. Decommissioning



Note: The device may only be taken out of service by trained specialist personnel. Before dismantling, ensure that the power supply is disconnected.

15. Disposal



The TOF-1S should only be replaced if a similar protection device is installed. Disposal should be done using the most up-to-date recycling technology according to local regulations and laws. There are no harmful materials used in the design and manufacture of the sensor. Traces of such dangerous materials may be found in the electronic components but not in the quantities that are harmful.